

DURAPOST® ALUMINIUM GATE KIT

Specification & FAQ's



DESCRIPTION

This stylish aluminium gate is designed to work well with both our Durapost® fencing system and with any standard fencing. Constructed from EN/AW - 660 grade aluminium this gate is strong and secure and comes in three powder coated finishes: anthracite grey, sepia brown and olive grey.

Powder coating is mainly used for the coating and protection of metals. Polyester powder coating is a type of coating that is applied as a free-flowing dry powder. Unlike conventional liquid paint which is delivered via an evaporating solvent, powder coating is typically applied electrostatically and then cured under heat or with ultraviolet light. The powder is a thermoset polymer which is used to create a hard finish that is tougher than conventional paint. Polyester Powder Coatings offer durable decorative finishes in a wide range of colour, textures and gloss levels. They are formulated to provide maximum corrosion resistance, colour stability and gloss retention. They are suitable for interior and exterior use and entirely T.G.I.C. free (Triglycidyl Isocyanurate Crosslinkers).

DURAPOST GATE INFILL PANELS

The aluminium gate composite infill panels have the same profile as the DuraPost composite gravelboard and are constructed from the same materials; extruded from PVCu, manufactured and fully UV stabilised to BS EN ISO 21306-1:2019/>The material is extruded with a full through colour so if the board is damaged or scratched, the area is not clearly visible and will not cause any detrimental effects to the board.

Over the lifetime of the product a gradual minor loss of shine may be noticeable, but this will have not detrimental effect to the material.

Available in three matching colours to complement the DuraPost product range: Anthracite Grey RAL 7016, Olive Grey RAL 7002 and Sepia Brown RAL 8014.

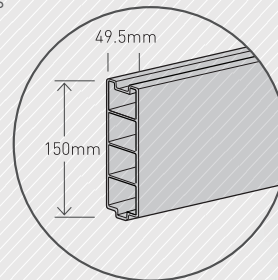

GATE FRAME & SLAM HINGE RECEIVERS

The gate frame is constructed from EN/AW - 660 grade aluminium, and powder coated. All powder coatings are salt spray tested to 1,000 hours to BS 3900F4, impact resistance to BS 3900E3, scratch resistance to BS 3900E2 and humidity minimum 1,000 hours to BS3900F2.



HINGES

The gate hinges are constructed from Grade 304, 3mm thick Stainless Steel.

The anti-theft design orients the hinges in such a way that the gate cannot be removed when closed.



DURAPOST®

ALUMINIUM GATE KIT

LOCK AND HANDLES

The gate is supplied with a DIN standard lock, to BS/EN 12209, with a 72mm centre, and 60mm back set.

A cylinder is also supplied, made in the UK, to BS/EN 1303:2005.

The catch direction can be easily switched simply by pulling out the catch and twisting.

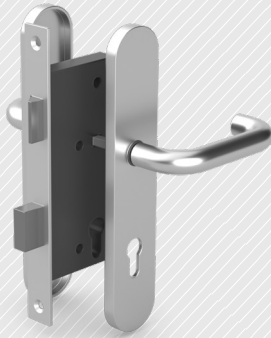

CORNER BRACKETS

The corner brackets are an integral part of the DuraPost Aluminium Gate, providing a rigid structure and a solid steel fixing point for the corners.

The steel packer and the black plastic packer work together with the steel bracket to provide accurate fixing points.



DIMENSIONS

| | |
|---------------------|--|
| Height: | 1.770m |
| Limits: | The max height is 1.770m, and can be reduced in increments of 150mm, down to a minimum of 1.320m |
| Width: | 1.188m (1.234m including slam hinge receivers) |
| Limits: | Max width is 1.188m, and can be cut down as far as needed. |
| Opening frame Size: | Max frame opening is 1.234m. If you are reducing the gate width, the opening needs to be gate width+46mm . Cleared Opening: |
| Min/Max: | The max cleared opening (for an unaltered gate) is 1.267m, and the minimum will depend on the extent to which it has been reduced. |
| Weight: | Approx 26kg |

FAQ'S

Can I reduce the size of that gate opening?

Yes - The maximum width is 1.188m, and can be reduced by cutting the top and bottom cross-rail down to the desired size with a chop-saw that has a new sharp metal-cutting blade.

What if I need to fix into timber?

The exact same method as would be used to fix to a DuraPost gate post can be used with a timber post.

What if the end plate is against a wall?

If the end plate is against a wall, you can fix the slam hinge receiver directly to the wall, but you will need a 4mm packer behind the receiver to make up for the lip.

What alternative infill panels can I use?

Any infill panel that fits into the opening is fine to use.

PART LIST

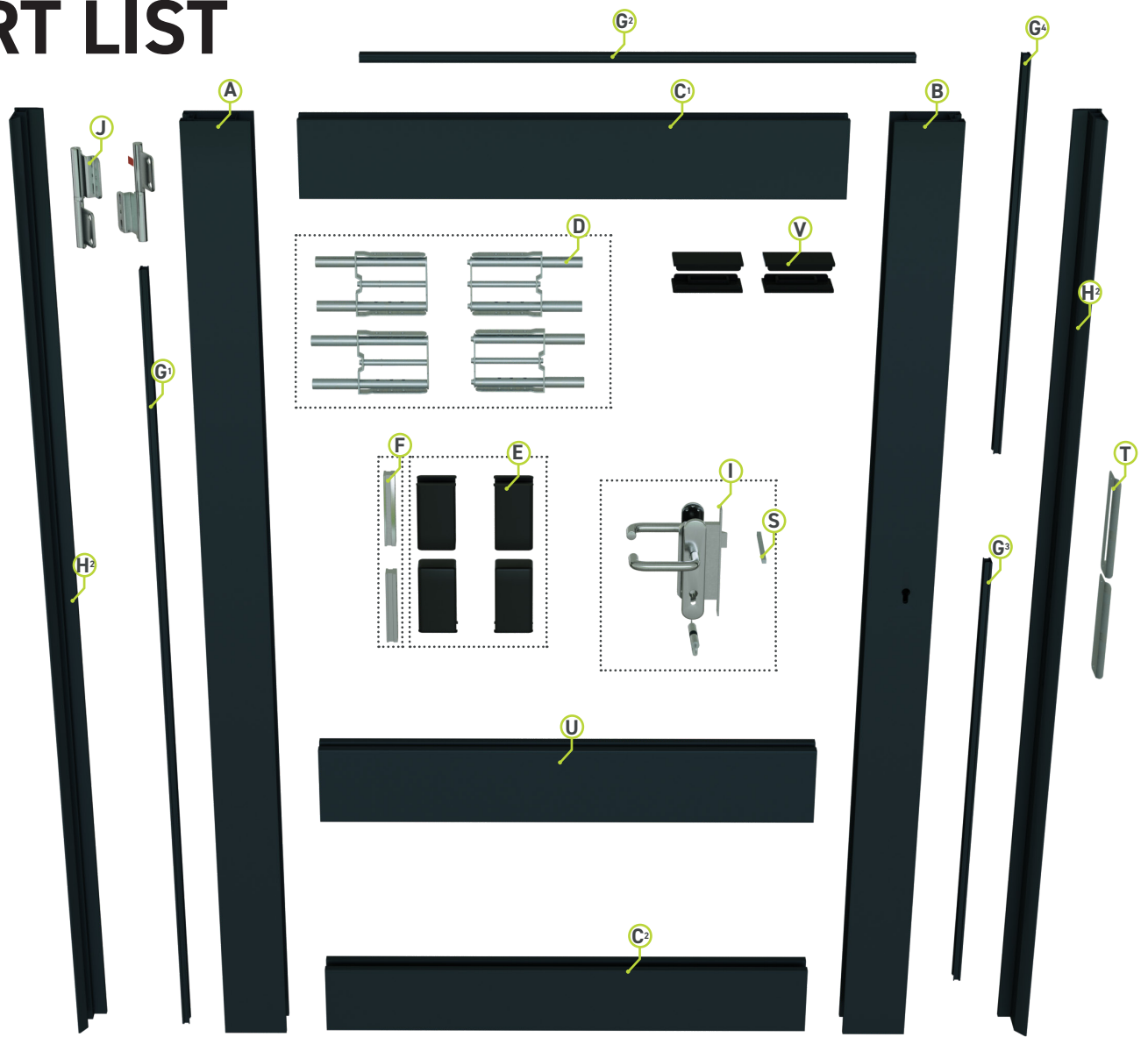

BOX 1

| | | |
|-----------|------|----------------------------------|
| A | (1x) | Upright Rail (hinge-side) |
| B | (1x) | Upright Rail (lock-side) |
| C1 | (1x) | Top Cross Rail |
| C2 | (1x) | Bottom Cross Rail |
| G1 | (1x) | Hinge-Side Cover Strip |
| G2 | (1x) | Top Cover Strip |
| G3 | (1x) | Below Lock Cover Strip |
| G4 | (1x) | Above Lock Cover Strip |
| H1 | (1x) | Slam Hinge Receiver (hinge-side) |
| H2 | (1x) | Slam Hinge Receiver (lock-side) |

BOX 3

| | | |
|----------|-------|-------------------------|
| U | (10x) | Composite Infill Panels |
|----------|-------|-------------------------|

BOX 2

| | | |
|----------|-------|---|
| D | (4x) | Corner Brackets |
| E | (4x) | Plastic Post Packers |
| F | (2x) | Steel Post Packers |
| I | (1x) | Lock & Handle Kit |
| J | (2x) | Hinge Set |
| K | (8x) | M8 X 16MM CAP HEAD ALLEN SCREW |
| L | (4x) | M8 X 40MM CAP HEAD ALLEN SCREW |
| M | (12x) | M8 WASHERS |
| N | (14x) | HEX HEAD SELF DRILLING SCREWS 5.5MM DIA X 25MM |
| O | (24x) | HEX HEAD SELF DRILLING SCREWS 5.5MM DIA X 30 MM |
| Q | (14x) | M4 X 32MM COUNTERSUNK PZ2 SINGLE THREAD |
| R | (6x) | M3 X 12MM COUNTERSUNK PZ2 |
| S | (1x) | Spindle |
| T | (2x) | Striker/Cover Strip |
| V | (4x) | End Caps |

DURAPOST®

ALUMINIUM GATE KIT

01 MEASURE WIDTH BETWEEN GATEPOSTS AND CUT RAILS/ INFILL PANELS

The exact width for the horizontal rails should be: (gate opening minus 256mm).

If cutting the rails, we recommend using a chopsaw with a new, sharp metal cutting blade. Remember to cut the infill panels to the same width.

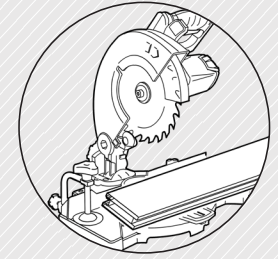
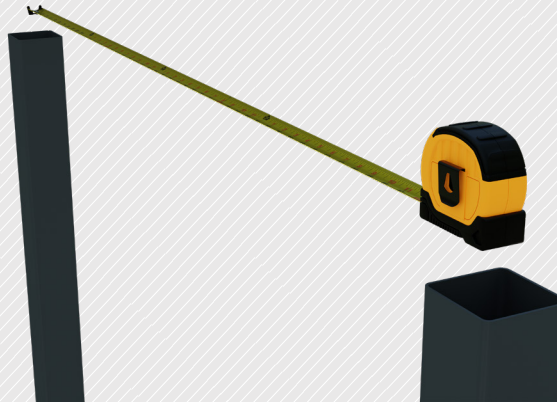

To reduce gate height cut uprights (A/B) down in 150mm increments.

02 SLOT CORNER BRACKETS INTO EITHER END OF TOP/ BOTTOM RAILS

It is very important to leave the brackets fully assembled (as they are packed) to ensure that all steel parts remain perfectly straight while fixing during the next step.

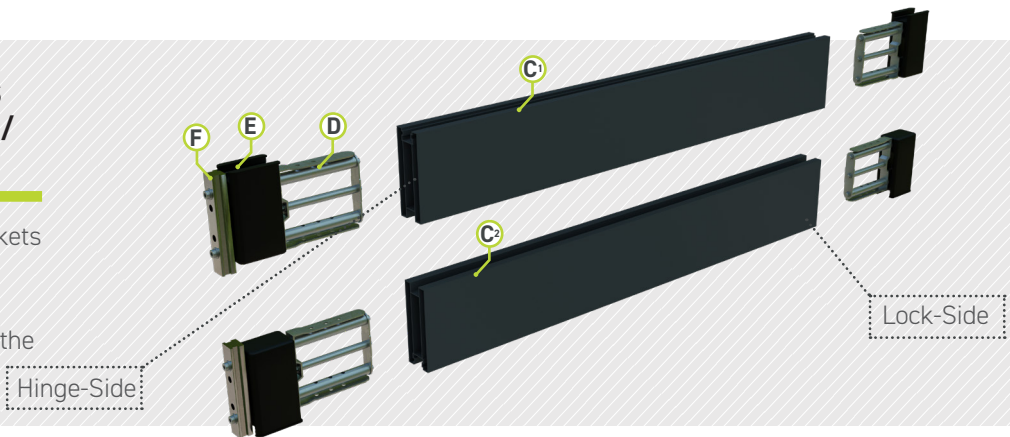

03 FIX THROUGH BRACKET 'STRAPS' INTO THE RAILS

Using the 5.5mm x 30mm hex head self drilling screws, fix through the pre-formed holes and into the aluminium rails.

IMPORTANT: DO NOT USE AN IMPACT DRIVER FOR THIS STEP IN ORDER TO PREVENT DAMAGE TO ANY SCREWS



04 REMOVE PLASTIC AND STEEL PACKERS

The plastic and steel packers may now be removed and set to one side for the next step.

You may discard the transit fixings.



05 PLACE PLASTIC PACKERS IN UPRIGHTS

Use the black plastic packers from the previous step.

These packers can only be fitted one way - simply slide into place.

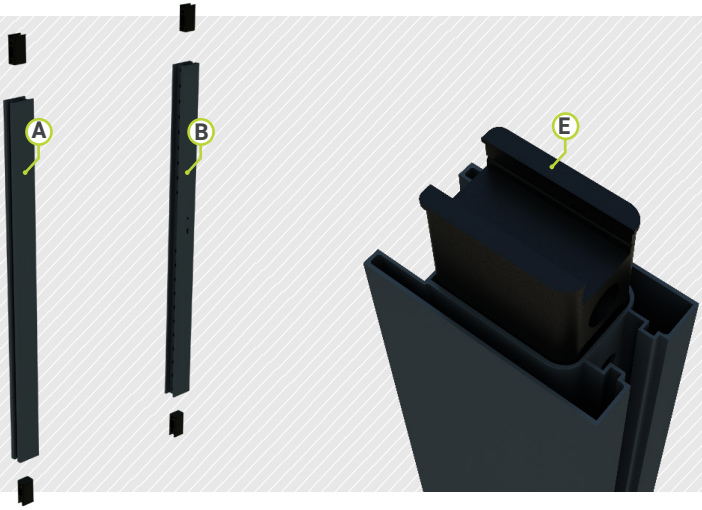

06 SLOT THE RAILS INTO THE 'HINGE-SIDE' UPRIGHT

The 'hinge-side' upright (A) can easily be identified as it will not have lock/handle holes.

Ensure that the detailed profile is facing outwards, i.e.: up at the top, down at the bottom.

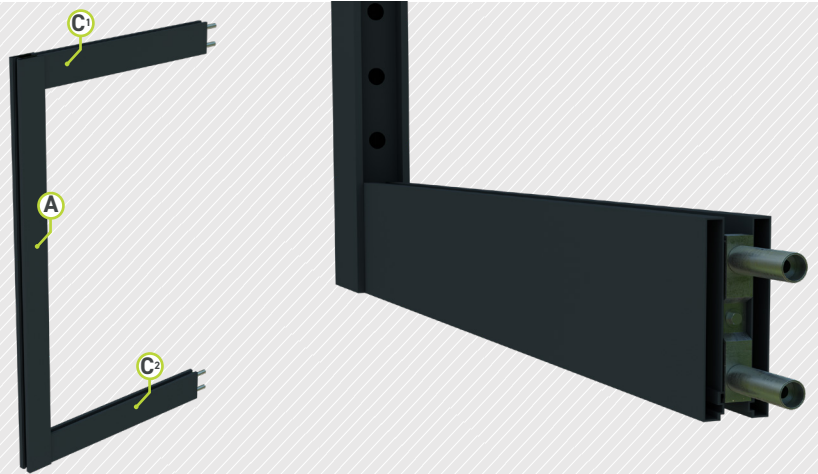

07 FIT AND FIX THE BOTTOM STEEL PACKER

With the steel packer in place the holes will line up and you can now screw through the outer two holes with 2 (L) M8 x 40mm Cap Head Allen screws.

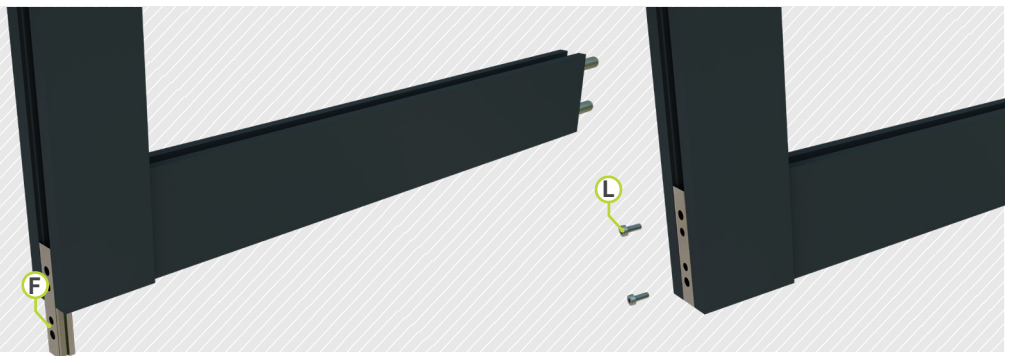

08 SLIDE THE COVER STRIP INTO PLACE AND THEN FIX THE OTHER STEEL PACKER

With the top steel packer in place the holes will line up and you can now screw through the outer two holes with 2 (L) M8 x 16mm Cap Head Allen screws, as in the previous step.

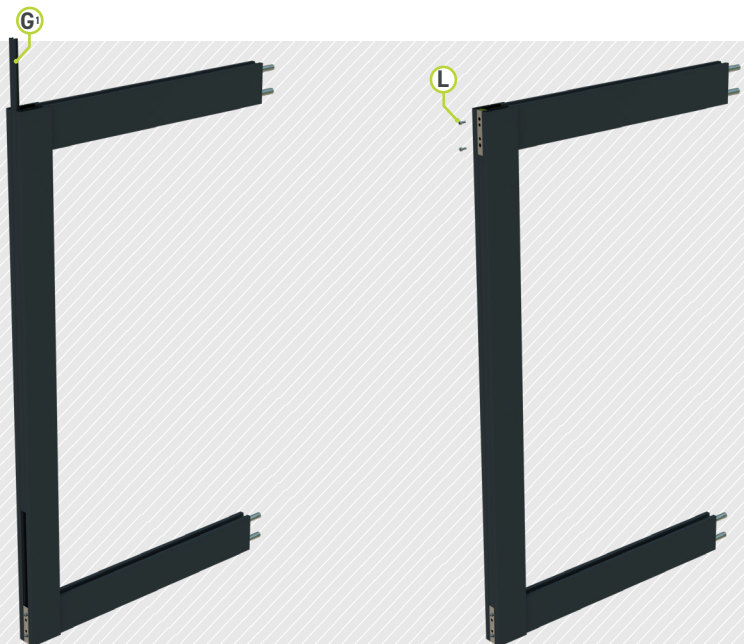

09 STACK THE INFILL PANELS IN THE OPENING

There are no fixing's required for this stage.

We recommend placing the infill panels with the groove facing upwards.

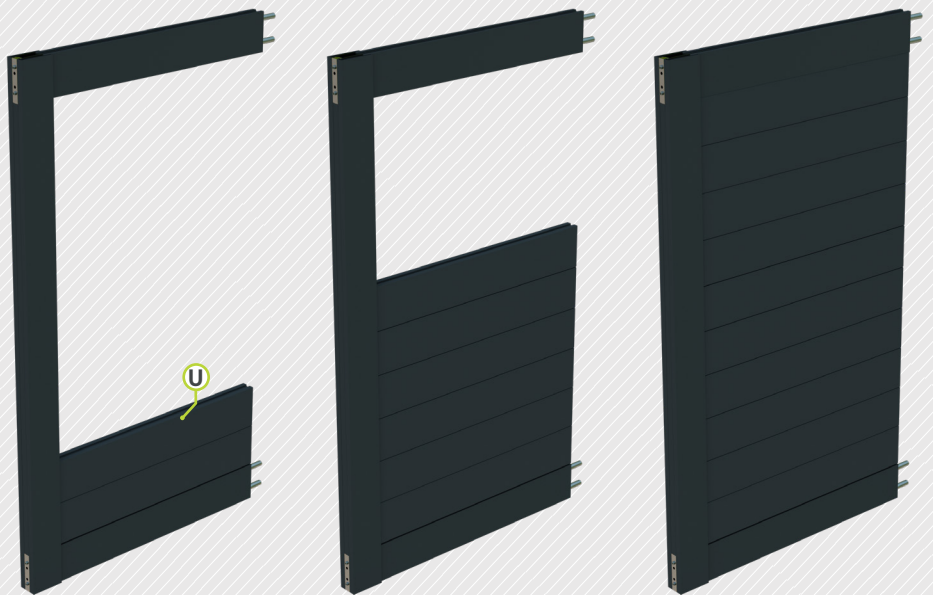

10 FIT THE TOP COVER STRIP & BOTTOM END CAPS, THEN LOCK-SIDE UPRIGHT

The cover strip (G2) must be in place before the other upright is fixed. It is not possible afterwards.

Once the lock-side upright is slid onto the 'arms' of the corner brackets, fix through using (K) M8 x 16mm Cap Head Allen screws (2 at the top and 2 at the bottom).

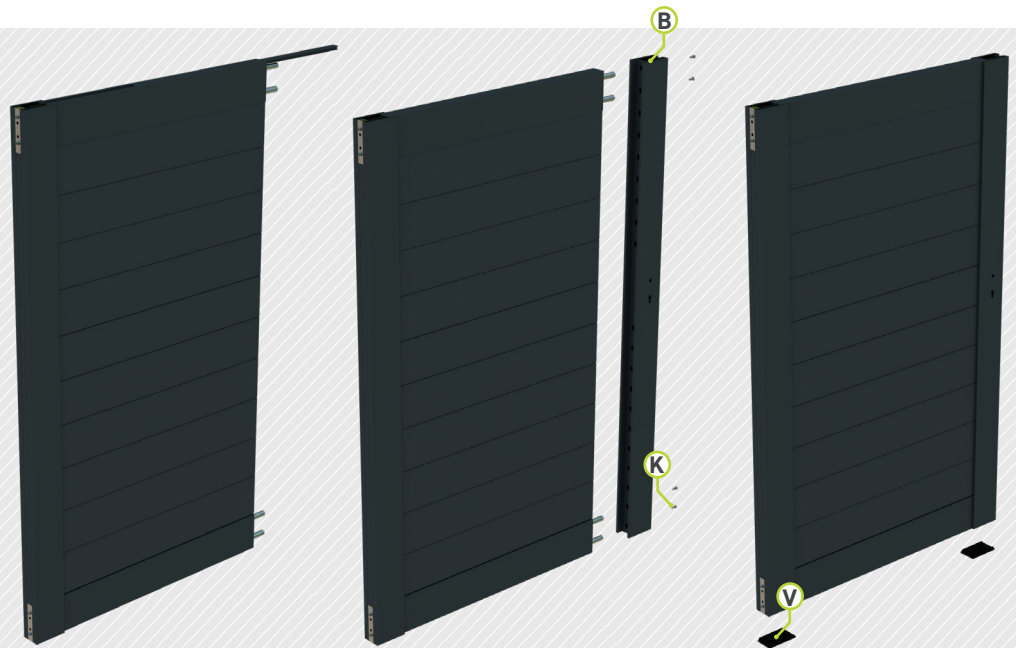

11 FIT COVER STRIP & LOCK MECHANISM

The cover strip (G3) must be slid into place before the locking mechanism.

Place the mechanism into the opening, then make a mark through the screw holes.

Remove the mechanism and pre drill the aluminium with a 3mm metal bit before fixing with (Q) M4 x 32mm Countersunk PZ2 screws (provided in the same box).

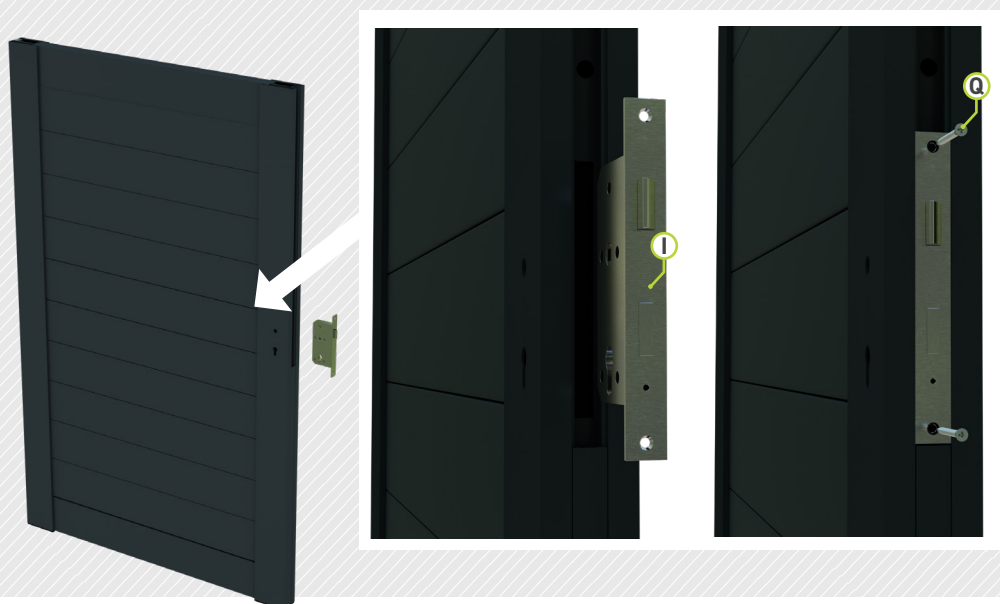

12 FIT LAST COVER STRIP & END CAPS

There are no fixings required for this stage.

Slide the last cover strip (G4) in place.

The end caps clip in with a small amount of pressure or a gentle tap from your hand.

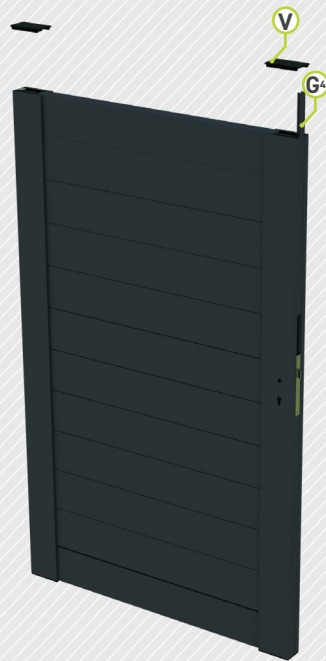

13 LOOSEN THE HANDLE FACEPLATE

The handle faceplate can be loosened by holding the handle and knocking the bottom of the faceplate gently but firmly against a hard surface several times.

Use a rag or cloth to prevent scratches.

Repeat this process with both handles.

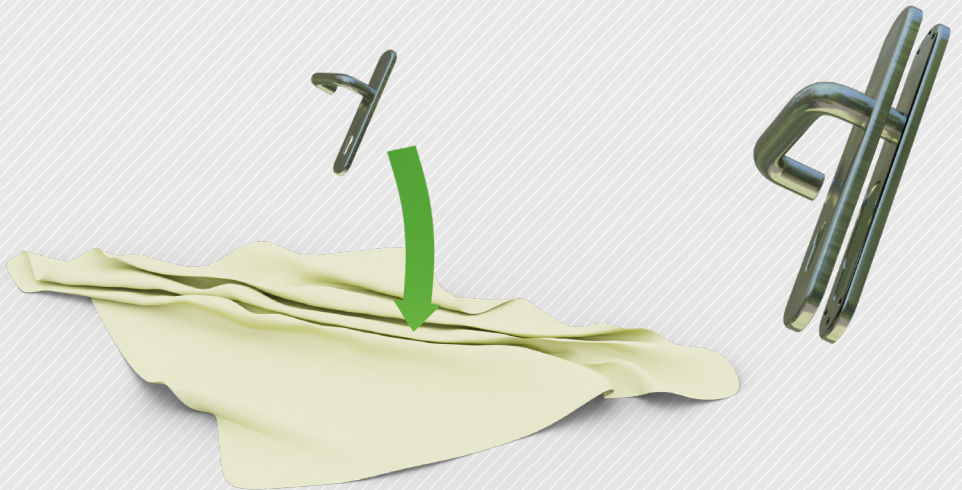

14 FIT SPINDLE & CYLINDER

The square spindle and cylinder can be slid through their respective openings until evenly spaced.

You will need to turn the key in the cylinder to close the cam and allow it to fit through.



15 SCREW IN CYLINDER AND FIT HANDLES

Screw through the single faceplate hole with the long screw (provided in the same box), into the corresponding hole in the cylinder, locking it tight in place.

Both handles can be fitted onto the square spindle.

Mark through the holes in the handle face-plates before pre drilling with a 3mm metal bit.

Screw in using (Q) M4 x 32mm Countersunk PZ2 screws and then slide the faceplates back on.

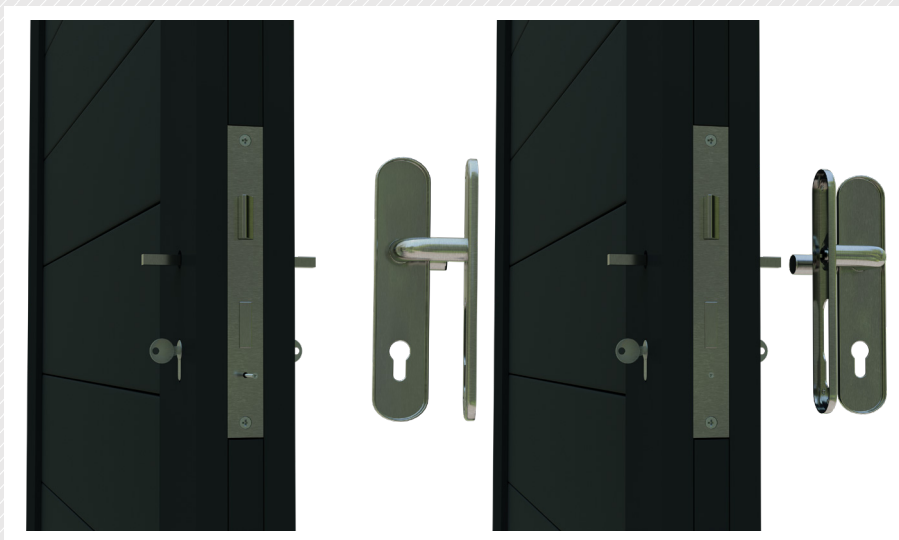

16 FIT SLAM HINGES TO POSTS

Place the slam hinge receivers against the post so that the tops line up. Make a mark through the screw holes, and then pre drill the post with a 3mm metal bit.

Then fix in place with (N) 5.5mm x 25mm Hex Head Self Drilling screws.

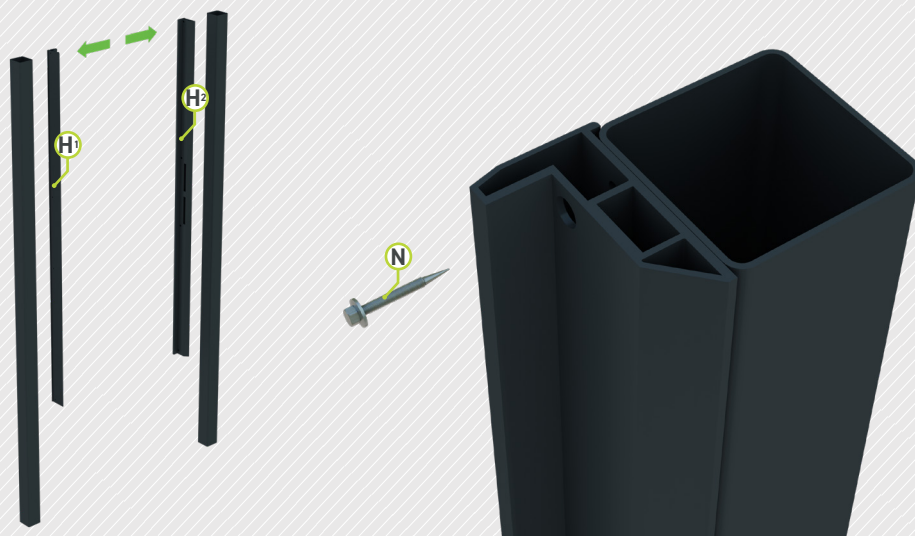

17 FIT HINGES

When fitting the hinges, it is extremely important to place the flat part of the hinge the correct way around. The opening in the roll must face the slam hinge receiver.

The red stickers identify the face that is to be hidden.



18 HANG GATE

The easiest way to hang the gate is to line up the top hinge with the slam hinge receiver, and then fix the loose piece.

The gate can then hang on the top hinge while the bottom is fixed in place.

To fix to the post, first pre-drill with a 3mm metal bit, then use (N) 5.5mm x 25mm Hex Head Self Drilling screws.

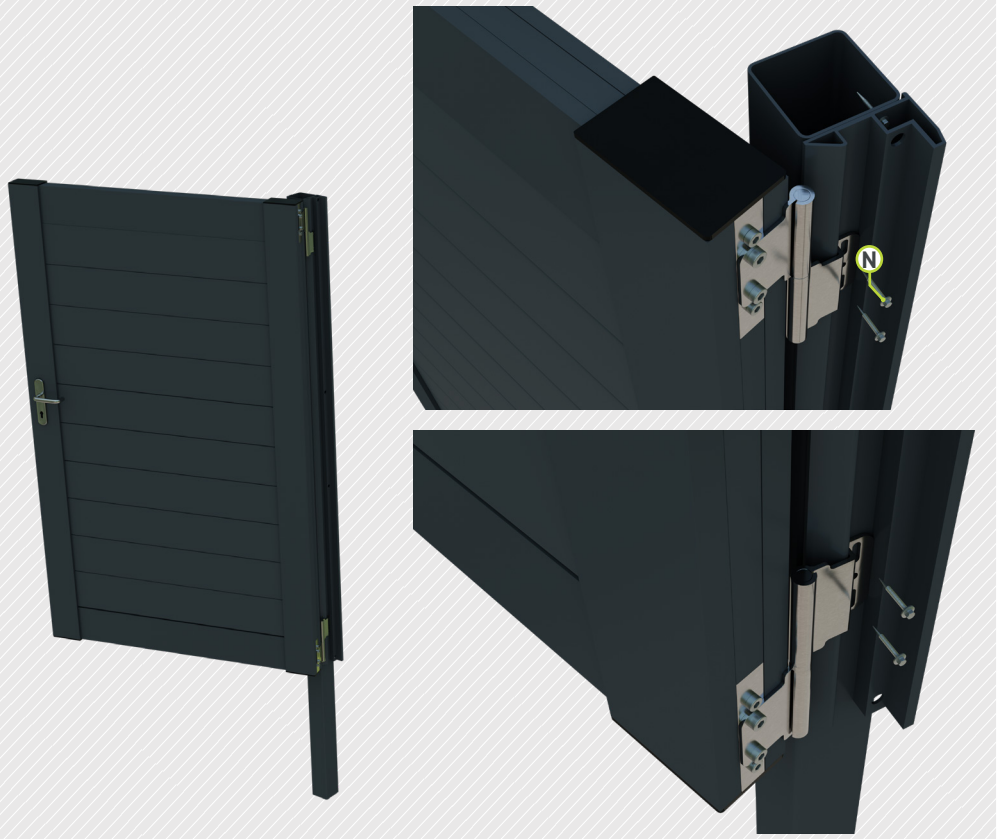

19 STRIKER AND COVER PLATE

The striker should be fitted in the top opening, and the cover plate over the bottom. Place in line with the hole and then bend the tabs inwards to hold in place.

Pre drill with a 2mm metal bit and then secure with (R) M3 x 12mm Countersunk PZ2 fixings.

